

# TOUGHSONIC<sup>®</sup> CHEM 35

## LIQUID OR SOLID CHEMICAL SENSOR



### DESCRIPTION

**CHEM** series sensors and WhitmanVIEW software put the power of ultrasonics in your hands. You can quickly adjust, optimize, save and clone your applications quickly without calibration! These sensors are housed in a rugged, chemically inert PVDF sealed housing for long life. They mount above the material surface and measure distance downward without contact. Outputs respond to that measured distance. Applications include pump control, bulk inventory, batch processing, water management and high/low level alarms.

### FEATURES

#### Level Measurement

- Long and short measurement
- Unaffected by optical factors like color and transparency
- Computer (PC) software allows remote adjustment

#### Packaging & Performance

- Durable housing for long life
- Bottom and top thread mounts
- Short & overload protected I/O
- Adjustable filters compensate for tank mixers or turbulence
- Temperature compensation for improved accuracy
- Adjustable sensitivity

#### Free Functionality

Use adjustable interface features like switch hysteresis and time delays to build complete solutions such as pump controls to maintain level. Save cost by eliminating PLCs, delay circuits and time delay relays!

### PC SETUP POWER!

Use WhitmanVIEW software (see separate data sheet) to adjust all sensor features. You can view, analyze or log data to optimize your application. Disconnect and the sensor retains the setup.

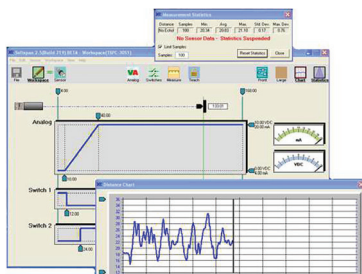

### Copy without Calibration

Application setups can be saved for future recall. From a single sensor inventory part you can quickly clone sensors, without recalibration, for any number of different field installations.

### MULTIPLE OUTPUTS

In addition to the model's serial data interface there are five simultaneous outputs, fully configurable with WhitmanVIEW.

#### Analog Outputs (3)

These include voltage (0-10 VDC) and two current loops (4-20 mA sinking and sourcing). Both output types have user selectable voltage/current ranges and endpoints for best resolution. Easily invert the analog output slope.

#### Switches (2)

Two switches are WhitmanVIEW configurable as "PNP" or "NPN" type (sourcing or sinking). Each has adjustable set point, hysteresis, window, initial conditions, ON delay, OFF delay and loss of target response to easily create controls and alarms!

#### Level or Height

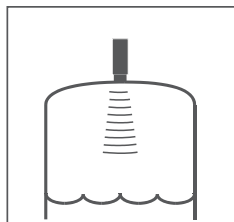

#### Solids Level

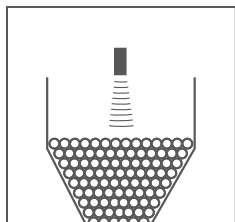

#### Environmental

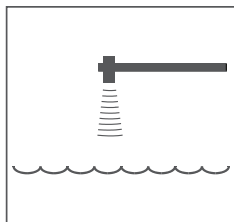

## PERFORMANCE SPECIFICATIONS

<b>Optimum Range</b>	25 ft. (7.6 m)	<b>Max Range</b>	35 feet (10.7 m)
<b>Deadband</b>	Typ. < 12 in. (30.5 cm)	<b>Adjustment</b>	WhitmanVIEW software
<b>Case Material</b>	PVDF	<b>Configuration</b>	Stored in non-volatile memory
<b>Temperature</b>	-40 to 158 F (-40 to 70 C)	<b>Outputs</b>	Five selectable, plus serial data
<b>Humidity</b>	0 to 100% operating	<b>Transducer</b>	Rugged piezoelectric
<b>Compensation</b>	Temperature compensated	<b>Protection</b>	NEMA-4X, NEMA-6P, IP68
<b>Resolution</b>	Digital: 0.0034 in. (0.086 mm); Analog: 4099 steps (0-10 VDC), 3279 steps (4-20 mA)		
<b>Repeatability</b>	Nominal 0.2% of range @ constant temp. Affected by target, distance, environment		
<b>Update Rate</b>	5 Hz (200 ms), WhitmanVIEW adjustable; affected by WhitmanVIEW filter selections		
<b>Voltage Output</b>	0-10, 0-5 VDC or PC customized; 10 mA max. (*)		
<b>Current Loop #1</b>	Current sourcing 4-20 mA or PC customized, max. loop 450! (*)		
<b>Current Loop #2</b>	Current sinking 4-20 mA or PC customized, max. loop 450! (*)		
<b>Sinking Switch</b>	150 mA max. @ 40 VDC max., teachable set point & polarity, fault indication		
<b>Sourcing Switch</b>	150 mA max. @ input voltage, teachable set point & polarity, fault indication		
<b>RS-232, RS-485</b>	Modbus protocol, 9600-115200 baud (selectable), 8 data bits, 1 stop, no parity		

## Target Requirements

<b>Target</b>	Detects flat or irregular surfaces. Target surface must reflect sound back to sensor.
<b>Max. Distance</b>	Affected by size, shape, orientation of target (sound level reflected back to sensor), environment Restrict use to Optimum Range when using over a wide range of environmental conditions
<b>Granular Solids</b>	De-rate max range by 50%; range affected by material density and orientation
<b>Orientation</b>	Orient sensor beam perpendicular to target surface for best performance
<b>Optical</b>	Unaffected by target color, light level, transparency or other optical characteristics

## CABLE CONNECTIONS

Cable	Wire	Description
Power	Brown	10-30 VDC, 50 mA maximum; Typical: 45 mA @ 24 VDC (**)
Ground	Blue	Power and interface common
Voltage Output *	Violet	0-10 VDC, 0-5 VDC or custom end values between 0 and 10 VDC
Current Loop Output *	Green	4-20 mA sourcing (adjustable end values between 4 and 20 mA)
Current Loop Output *	Orange	4-20 mA sinking (adjustable end values between 4 and 20 mA)
Switch #1 Output	Black	Sinking ("NPN") or Sourcing ("PNP"), user selected
Switch #2 Output	White	Sinking ("NPN") or Sourcing ("PNP"), user selected
RS-232 out / RS-485-	Gray	Serial data connection (depends on model - see model selection)
RS-232 in / RS-485+	Yellow	Serial data connection (depends on model - see model selection)

(\*) Analog outputs share common distance endpoints. Both 4-20 mA outputs share the same adjustable max / min values.

The maximum loop resistance is derated below 15 VDC input voltage.

(\*\*) At default update rate. Output currents not included. Sensitivity reduced below 15 VDC input voltage.

### PART NUMBERS

Model Number	Description
LVL-500-232	Serial RS-232 interface (PC COM port compatible)
LVL-500-485	Serial RS-485 interface (allows addressable multi-sensor networks)

Whitman also offers interconnection, communication, mounting, and display components

### DIMENSIONS

#### Mechanical

##### Mounting Threads:

Lower 2-in. Parallel  
Upper 1-in. NPT  
(optional 1-in. BSP or M32 x 1.5 metric by special order)

##### Attached Cable:

PUR jacket, 6.5ft (2 m) long

##### Weight:

24.7 oz. (0.70kg)

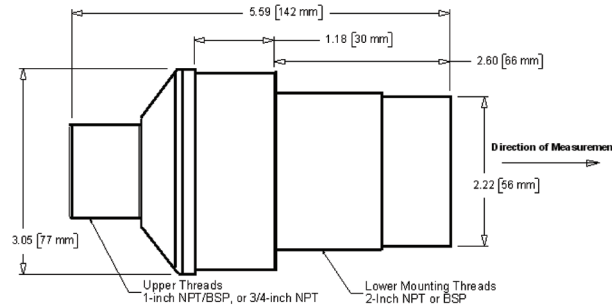

All rights reserved. Specifications subject to change without notice. Whitman products are not recommended for applications with hazardous or explosive materials, or as a primary device for personal safety. Copyright 2024 Rev. 8\_24

#### Whitman Controls, LLC

201 Dolphin Rd  
Bristol, CT 06010

**Phone:** +860-583-1847

**Fax:** +1-860-583-5293

#### For Sales Inquiries, Contact:

[sales@whitmancontrols.com](mailto:sales@whitmancontrols.com)

#### For Engineering Inquiries, Contact:

[engineering@whitmancontrols.com](mailto:engineering@whitmancontrols.com)

#### Call Toll Free Customer Service:

800-233-4401 Ext 120